

## Montage links: (Fahrtrichtung)

Kontrollieren Sie wenige Tage nach der Erstmontage den festen Sitz der Crash Balls und danach regelmäßig im Abstand von ca. 3 Monaten.  
Schrauben bei Bedarf nachziehen, das Anzugsdrehmoment beträgt 10Nm

Endfest vormontieren und von links in die Hinterachse einsetzen.

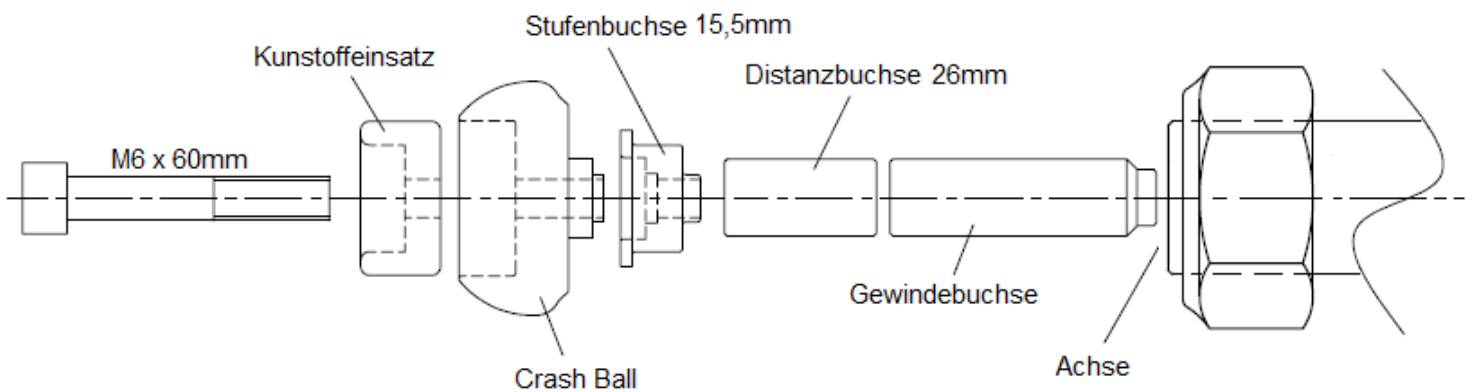

## Montage rechts: (Fahrtrichtung)

Von rechts Achs Ball mit M6x290mm endfest montieren.

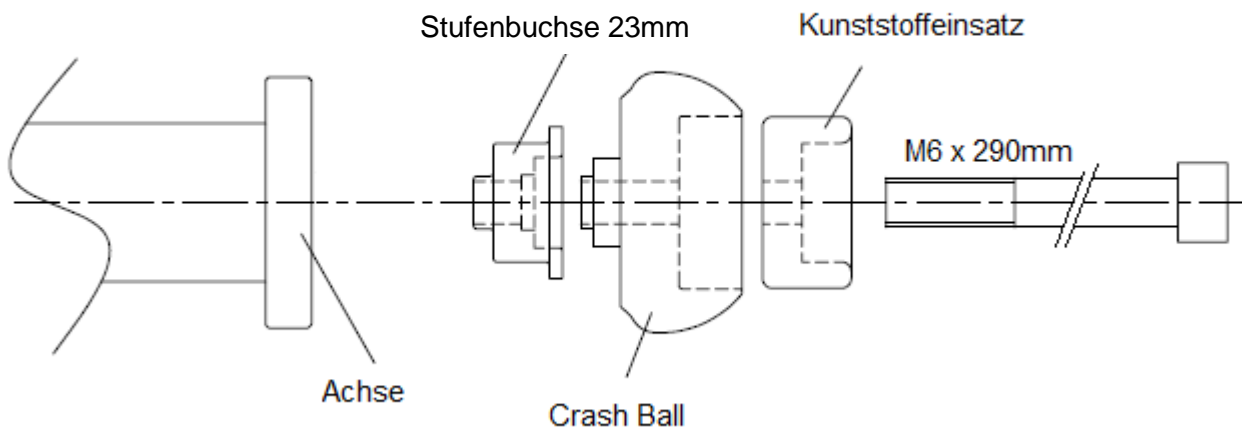



## Fitting Instruction 556Y139

### Fitting left: (driving direction)

Check the Crash Balls for proper fit a few days after first installation, then periodically every 3 month. Tighten them again if necessary. The tightening torque is 10Nm / 7.37lbf ft.

Mount this parts first and tighten them finaly, then insert them into the axle.

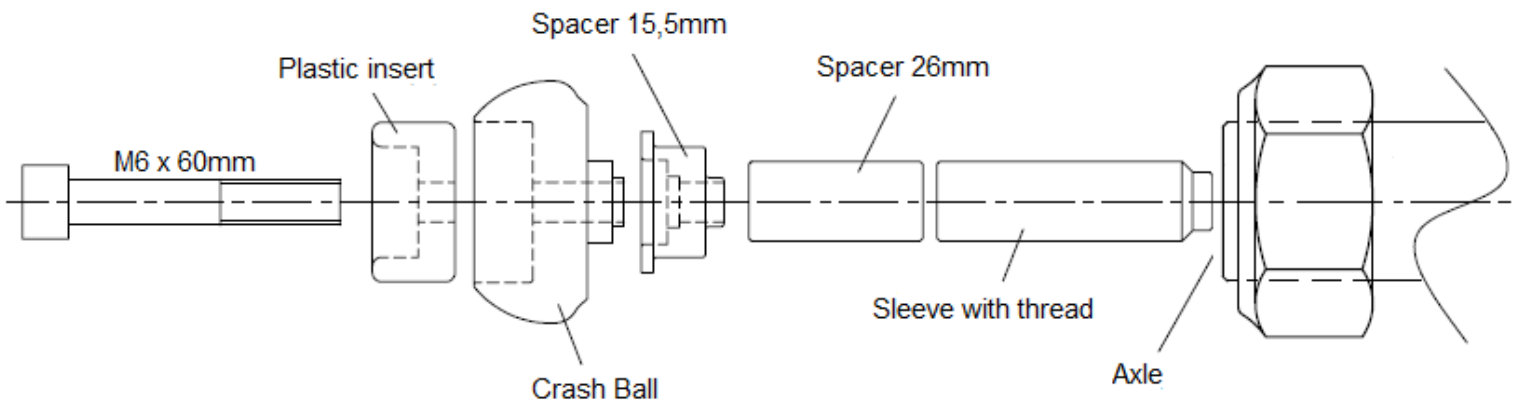

### Fitting right: (driving direction)

From the right, mount the Crash ball with M6x290mm finaly.

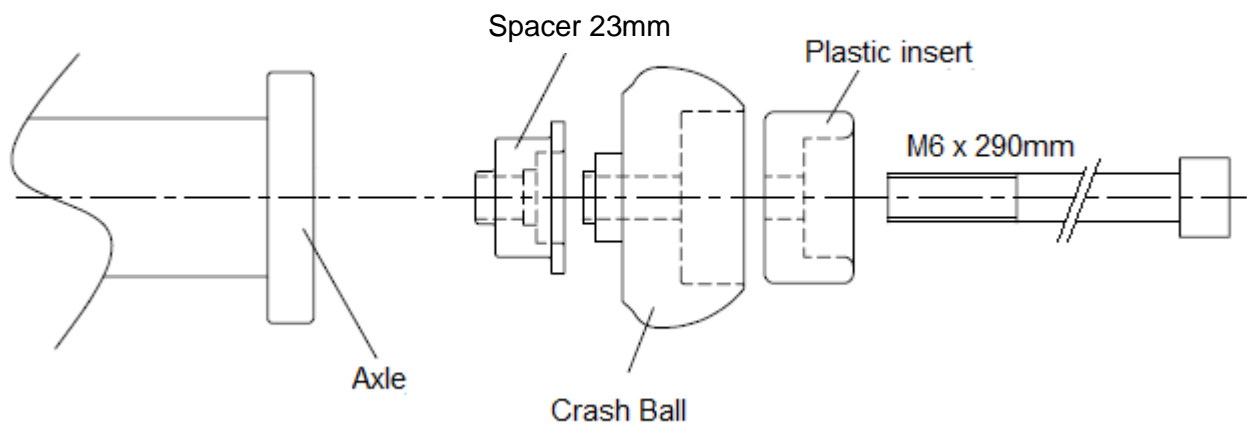



## Notice de montage 556Y139

### Montage gauche: (sens de la marche)

Contrôlez le serrage quelques jours après le premier montage, puis régulièrement, tous les Trois mois environ. Serrez les visa un couple de serrage de 10Nm

Commencez par le montage des pièces avant de les pousser sur l'axe !

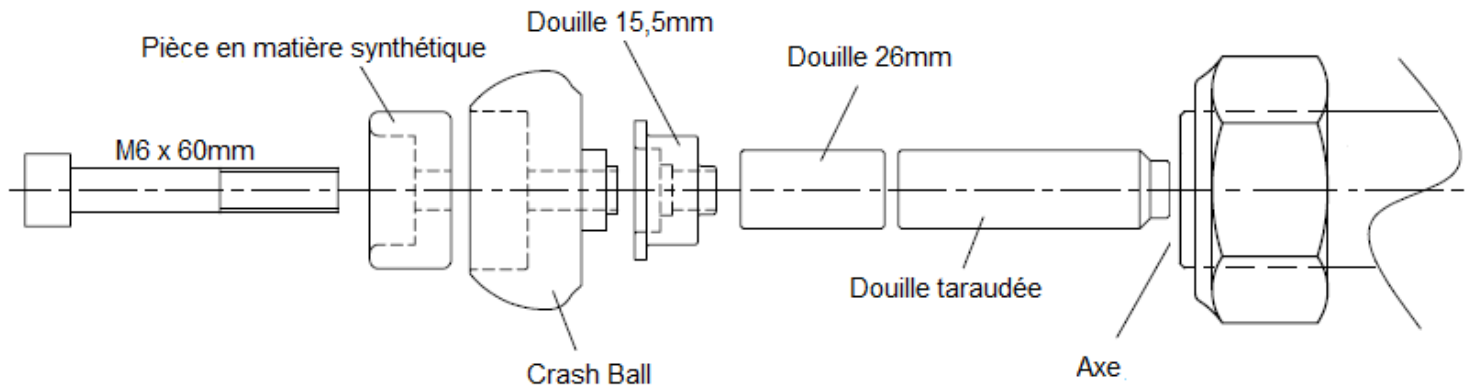

### Montage droit: (sens de la marche)

Serrer l'Crash Ball avec la vis M6x290mm depuis la droite.

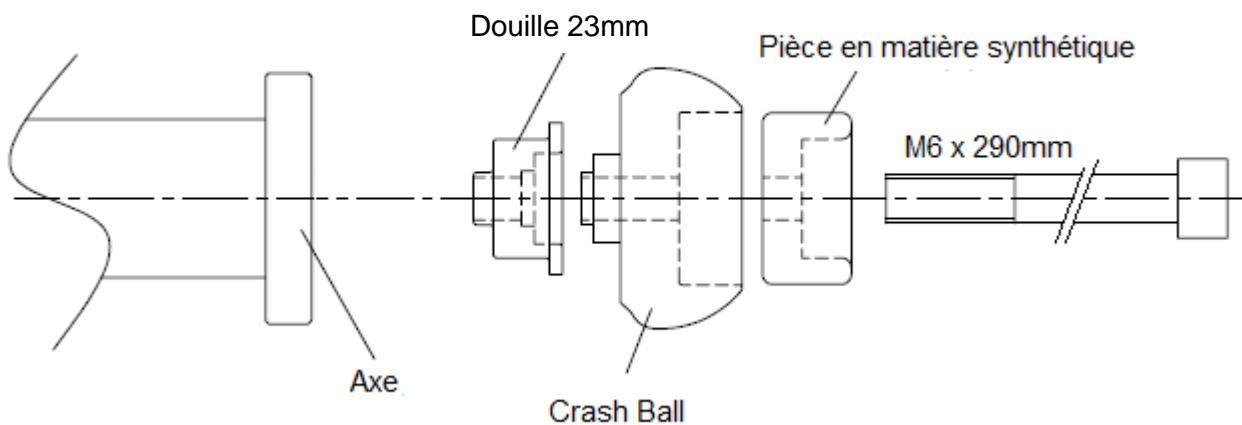



**LSL-Motorradtechnik GmbH • D-47809 Krefeld**

**[www.lsl.eu](http://www.lsl.eu)**