

Anbauhinweise Crash Ball Achsprotectoren Art.-Nr.: 556K150..

Anbau rechts

Erst diese Teile endfest montieren und in die Achse schieben!

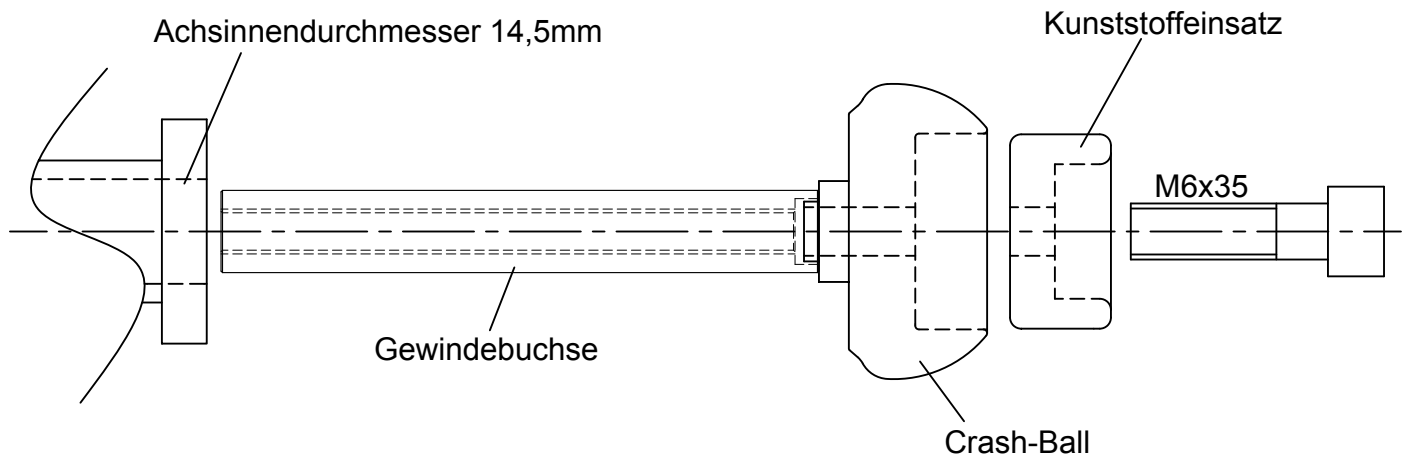

Anbau links

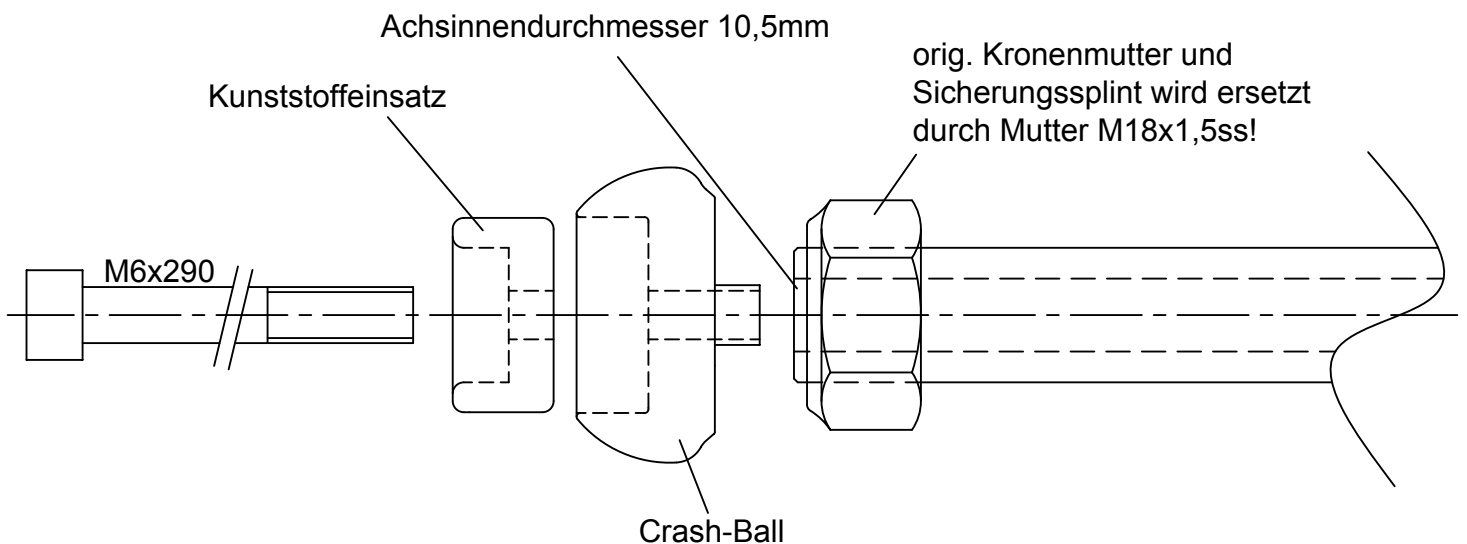

LSL-Motorradtechnik GmbH • D-47809 Krefeld

www.lsl.eu

Stand: 17.08.2015

Fitting instruction Crash Balls for axle protection part.-No.: 556K150..

Fitting right side

Mount this parts first and tighten them, then insert them into the axle!

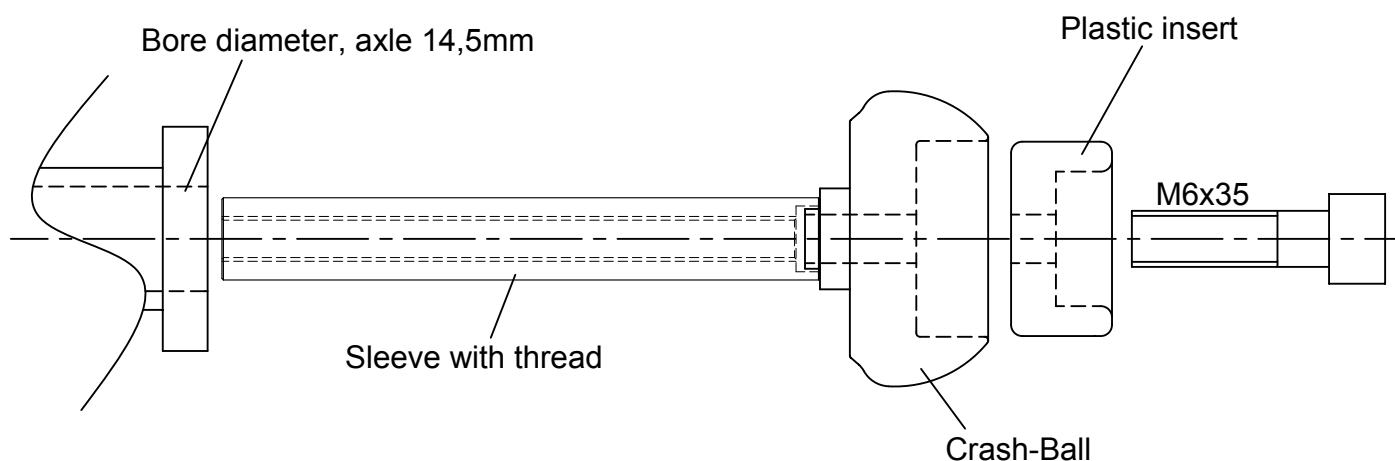

Fitting left side

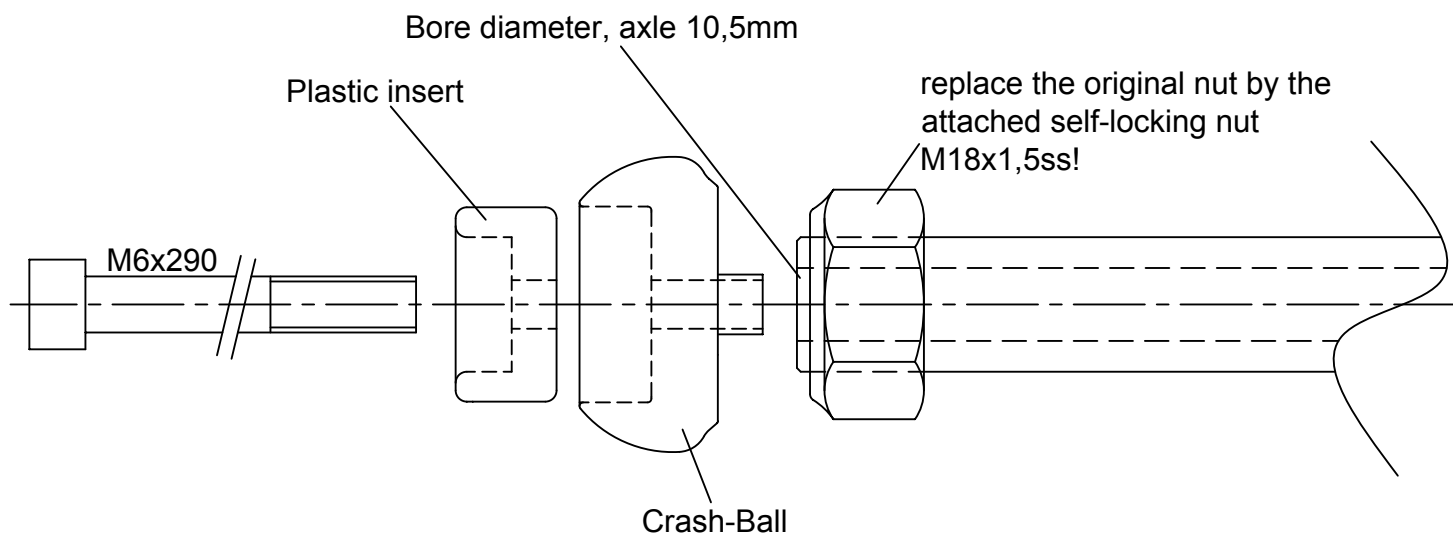

LSL-Motorradtechnik GmbH - D-47809 Kreßfeld

www.lsl.eu

Stand: 17.05.2015

Instructions de montage pour protecteurs d'axe Crash Ball

N° article: 556K150..

Montage droit

Commencez par le montage des pièces avant de les pousser sur l'axe!

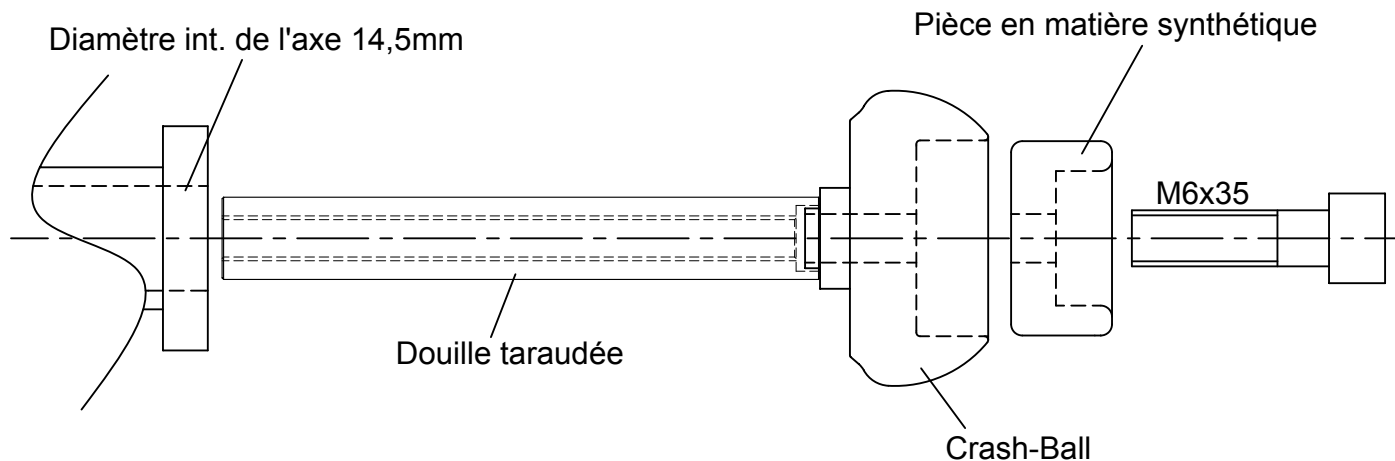

Montage gauche

