



Montageanleitung 555T037

Montage rechts: (Fahrtrichtung)

Kontrollieren Sie wenige Tage nach der Erstmontage den festen Sitz der Crash Balls und danach regelmäßig im Abstand von ca. 3 Monaten.

Schrauben bei Bedarf nachziehen, das Anzugsdrehmoment beträgt 10Nm

Zuerst rechte Seite montieren!

Hinweis:

Bei Triumph Daytona 675 ab 2009, Speed Triple 1050 S / R '16, Street Triple RS '17
seitenverkehrt montieren.

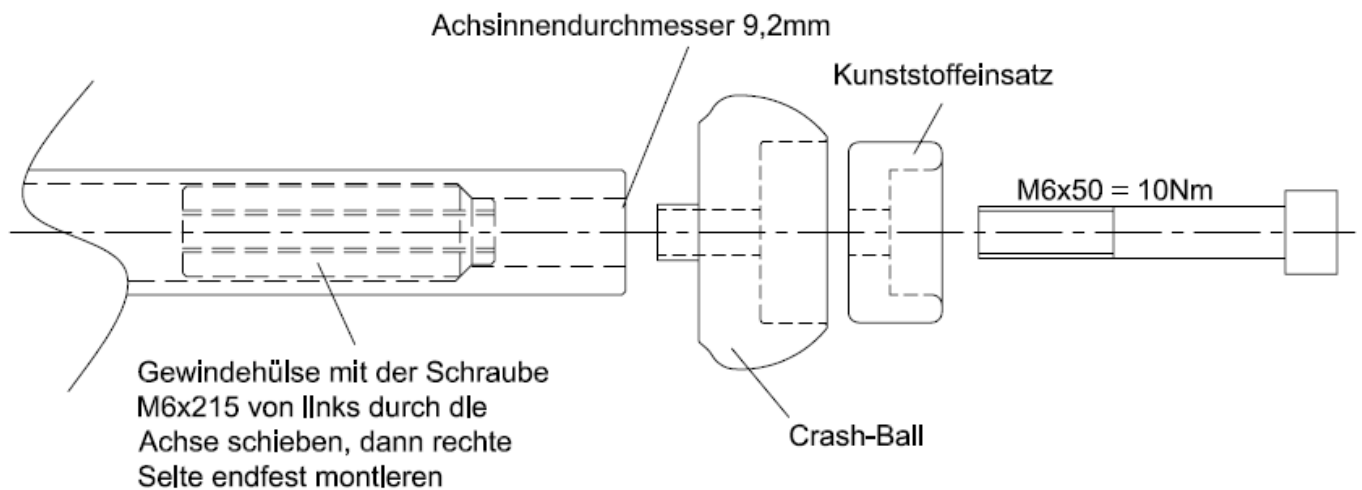

Montage links: (Fahrtrichtung)

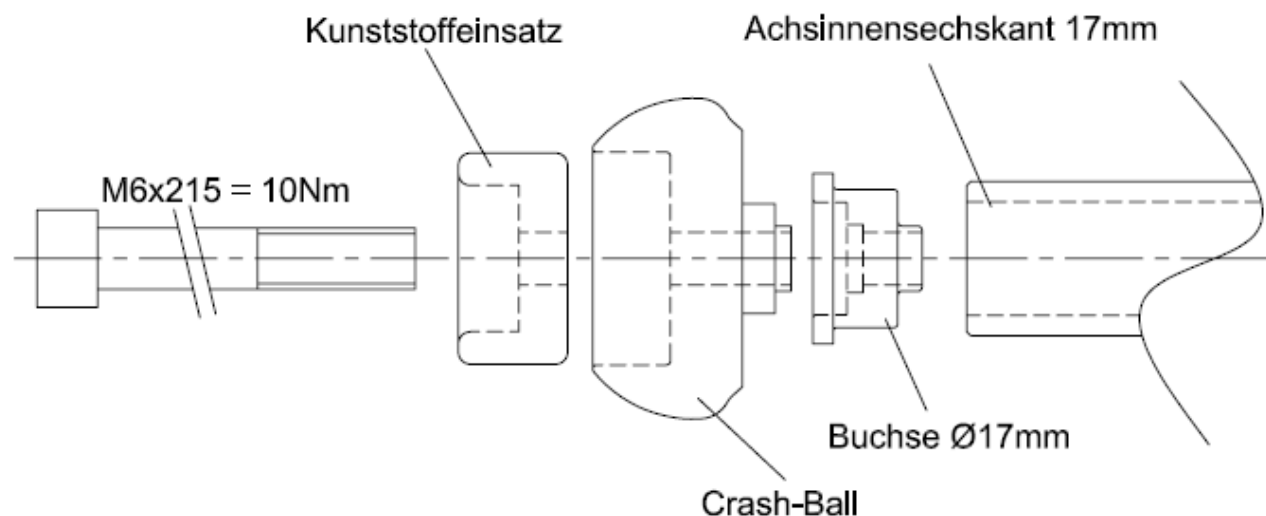



Fitting Instruction 555T037

Fitting right: (driving direction)

Check the Crash Balls for proper fit a few days after first installation, then periodically every 3 month. Tighten them again if necessary. The tightening torque is 10Nm / 7.37lbf ft.

Mount the right side at first!

Advice:

For Triumph Daytona 675 from 2009, Speed Triple 1050 S / R '16 - , Street Triple RS '17 -
mount vice versa!

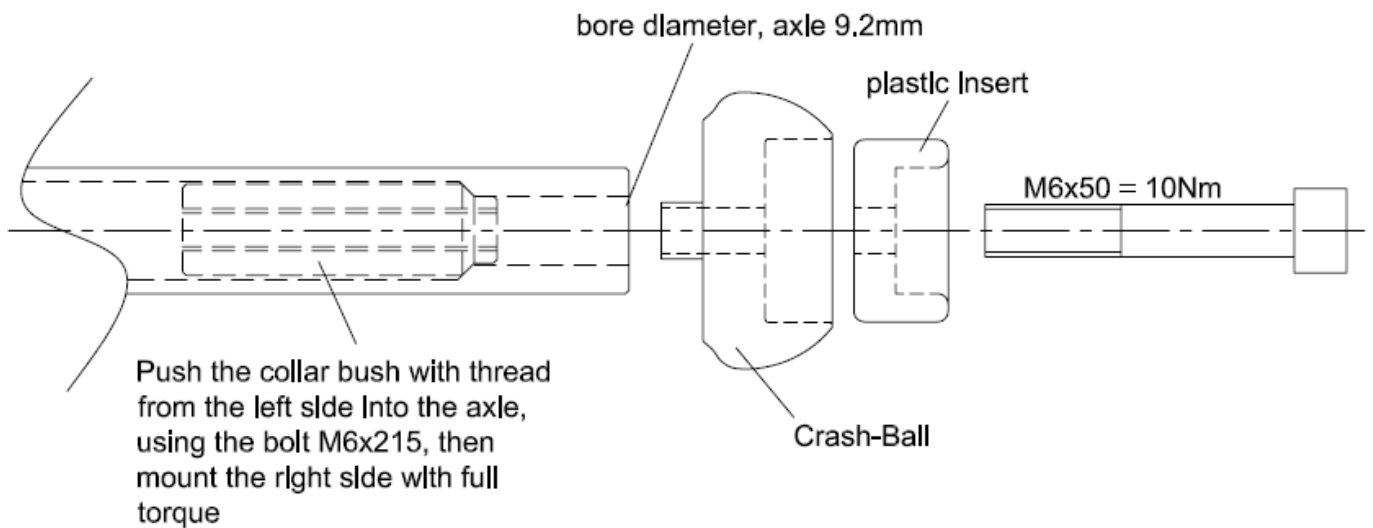

Fitting left: (driving direction)

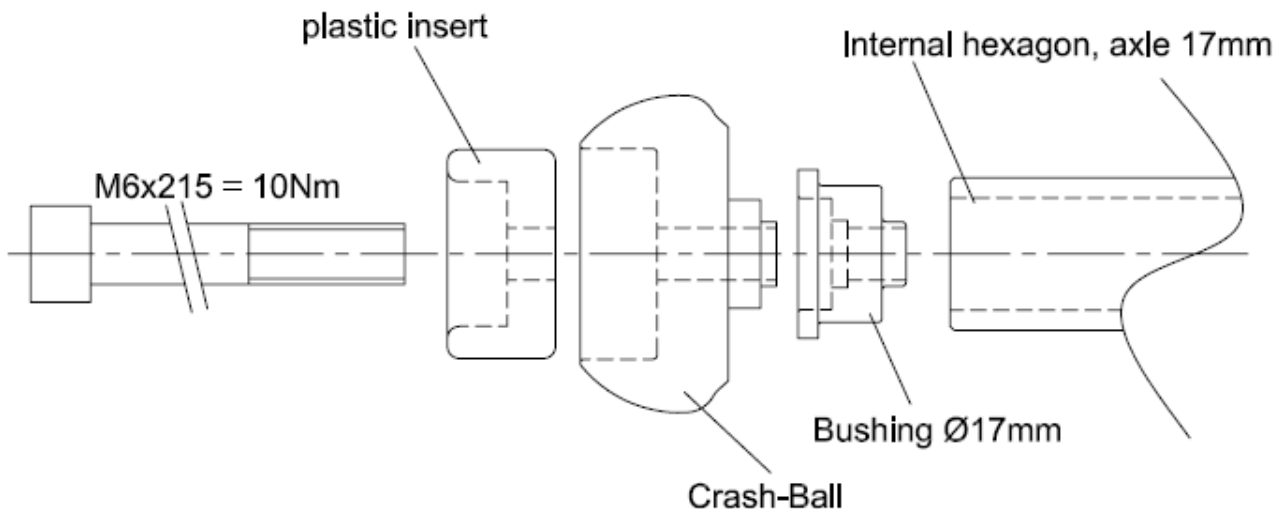



Notice de montage 555T037

Montage droit: (sens de la marche)

Contrôlez le serrage quelques jours après le premier montage, puis régulièrement, tous les Trois mois environ. Serrez les visa un couple de serrage de 10Nm

Faites le montage du côté droit en premier!

Avertissement:

Pour la Triumph Daytona 675 dès 2009, Speed Triple 1050 S / R '16 - , Street Triple RS '17 montage se fait à l'envers!

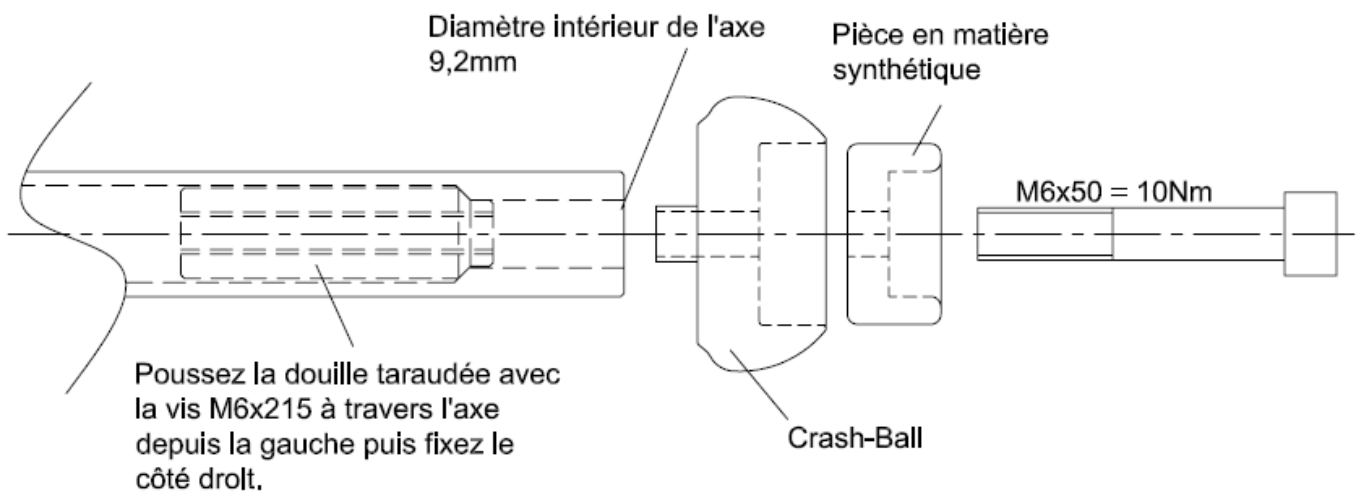

Montage gauche: (sens de la marche)

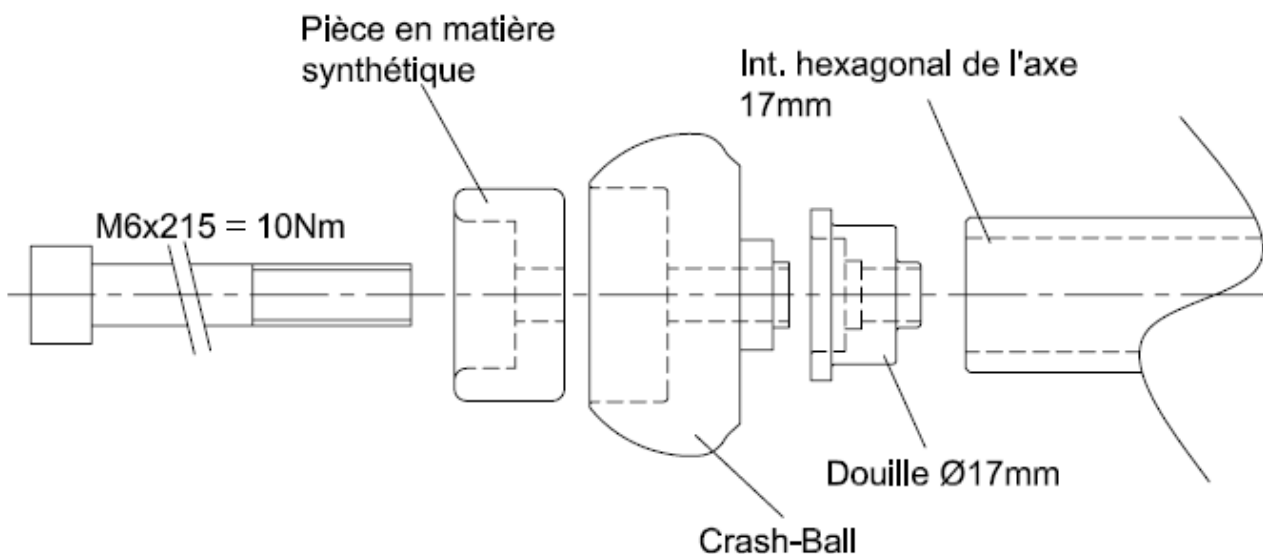



LSL-Motorradtechnik GmbH • D-47809 Krefeld

www.lsl.eu