

## Wichtige Montagehinweise:

Kontrollieren Sie wenige Tage nach der Erstmontage den festen Sitz der Crash Balls und danach regelmäßig im Abstand von ca. 3 Monaten. Schrauben bei Bedarf nachziehen, das Anzugsdrehmoment beträgt 10Nm

## Anbau vorne rechts

Erst diese Teile endfest montieren und in die Achse schieben!

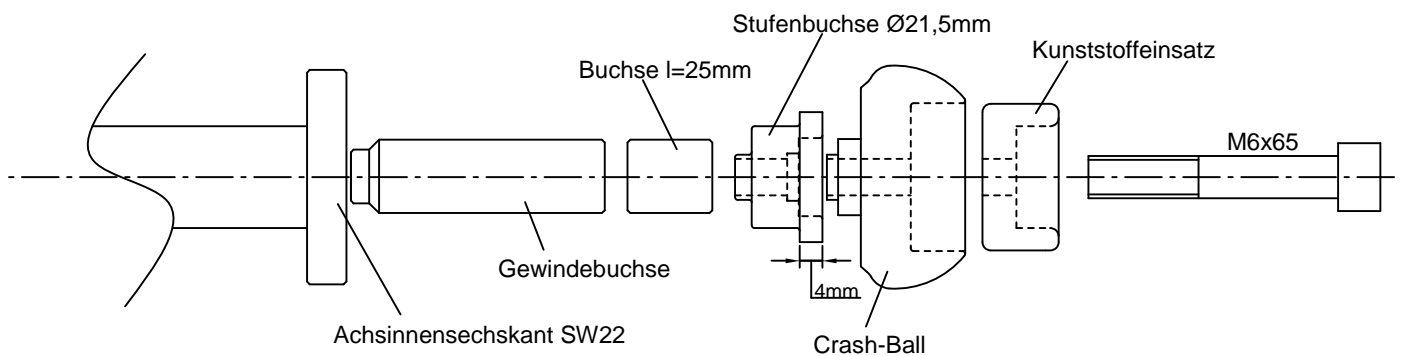

## Anbau vorne links

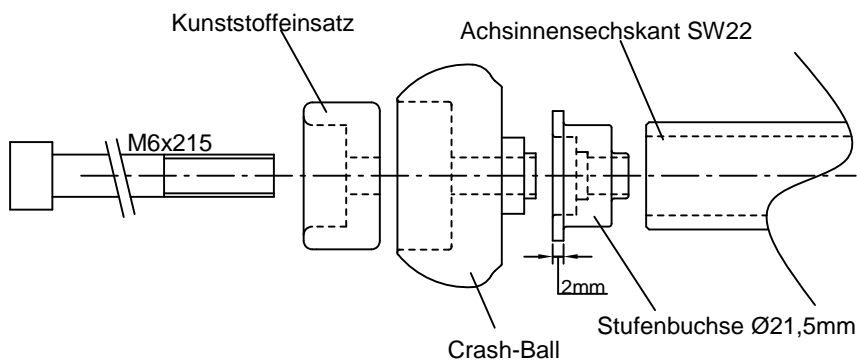

# Fitting instruction Crash Balls for axle protection    part-no.:555K101

## Important mounting instructions:

Check the Crash Balls for proper fit a few days after first installation, then periodically every 3 month. Tighten them again if necessary. The tightening torque is 10Nm / 7.37lbf ft.

## Fitting front, right side

**Mount this parts first and tighten them, then insert them into the axle!**

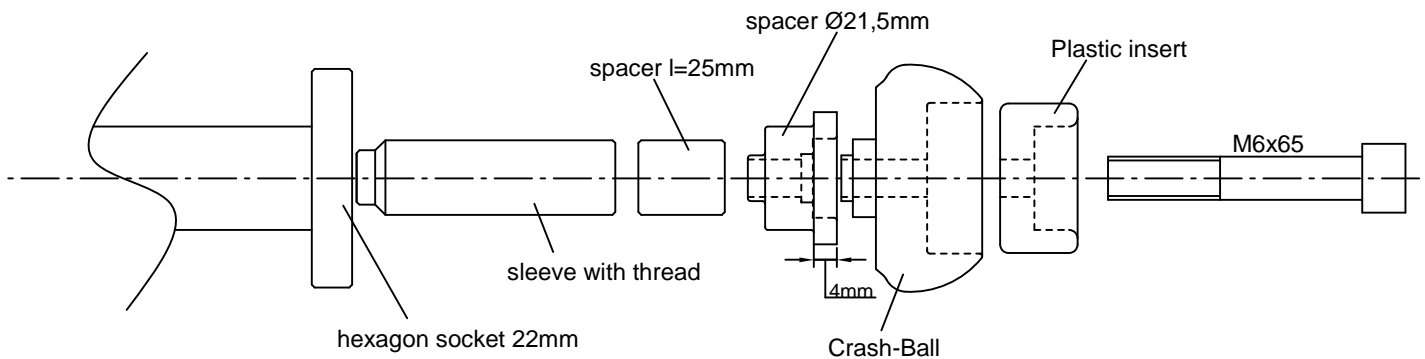

## Fitting front, left side

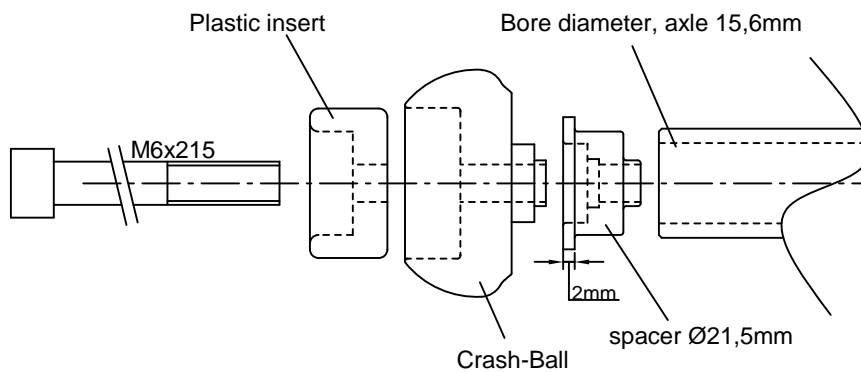

# Instructions de montage pour protecteurs d'axe Crash ball Art.- Nr.: 555K101

## Important:

Contrôlez le serrage quelques jours après le premier montage, puis régulièrement, tous les Trois mois environ. Serrez les visa un couple de serrage de 10Nm.

## Montage à l'avant droite

Commencez par le montage des pièces avant de les pousser sur l'axe!

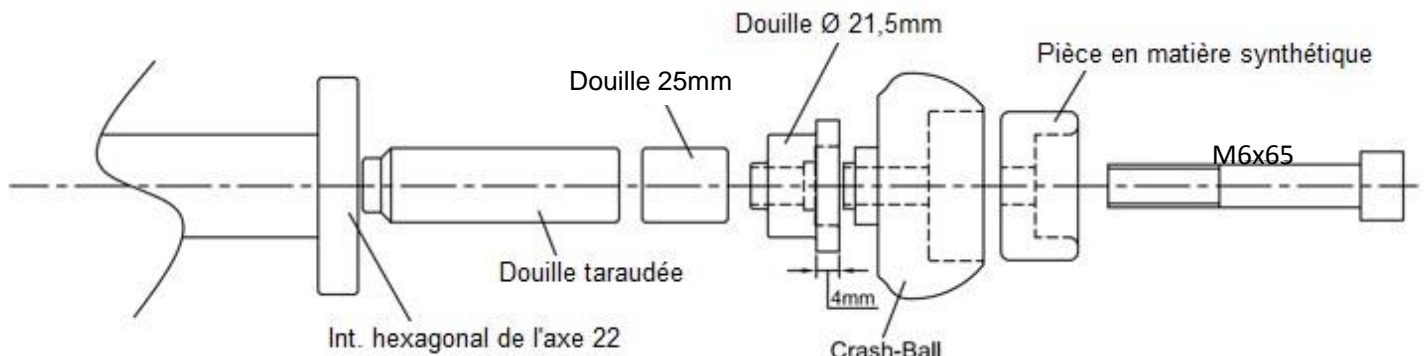

## Montage à l'avant gauche

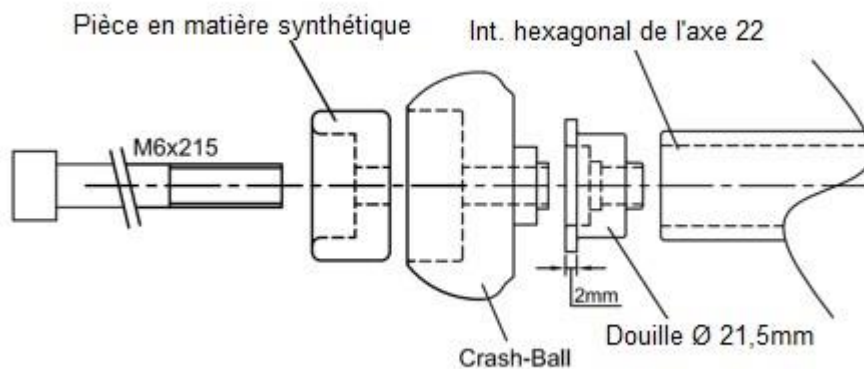

LSL-Motorradtechnik GmbH • D-47809 Krefeld

[www.lsl.eu](http://www.lsl.eu)

Rev.02 30.05.2016