

Wichtig: Wenn Sie kein ausgebildeter Mechaniker sind, wenden Sie sich bitte an eine Fachwerkstatt!
Anzugsdrehmoment Schrauben M6 und M8 lt. Herstellerangaben!

Anbau an der rechten Seite

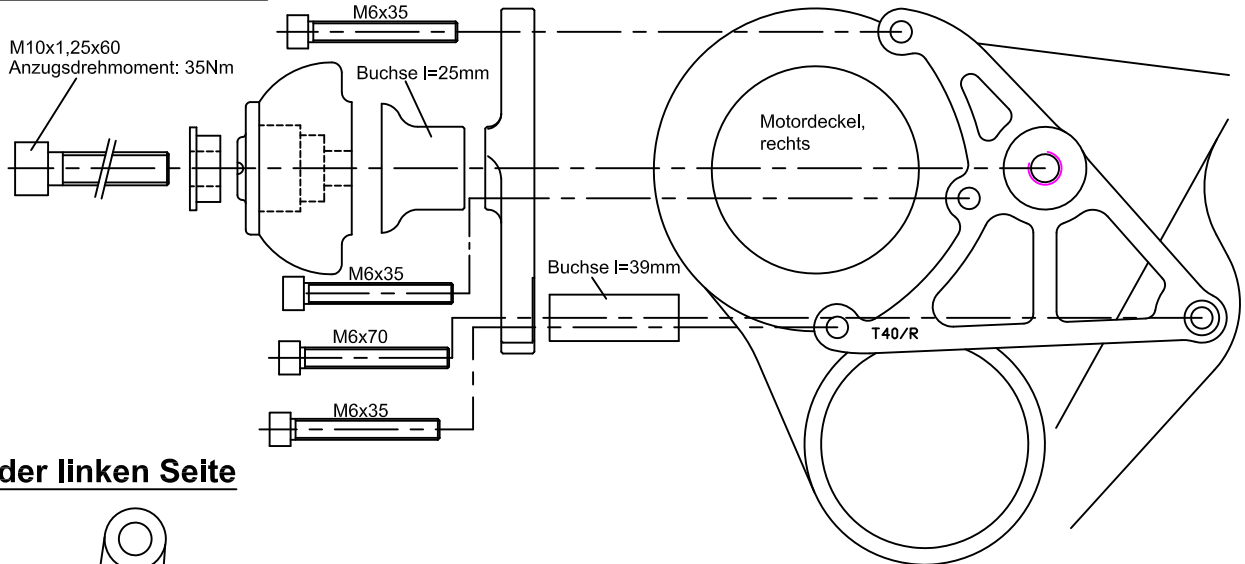

Anbau an der linken Seite

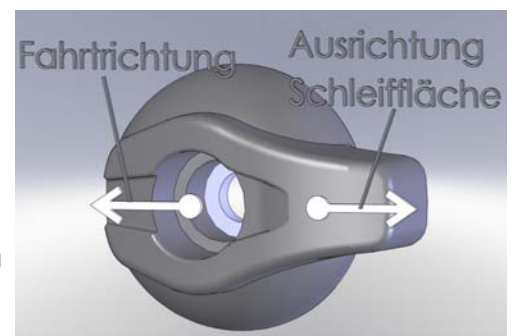
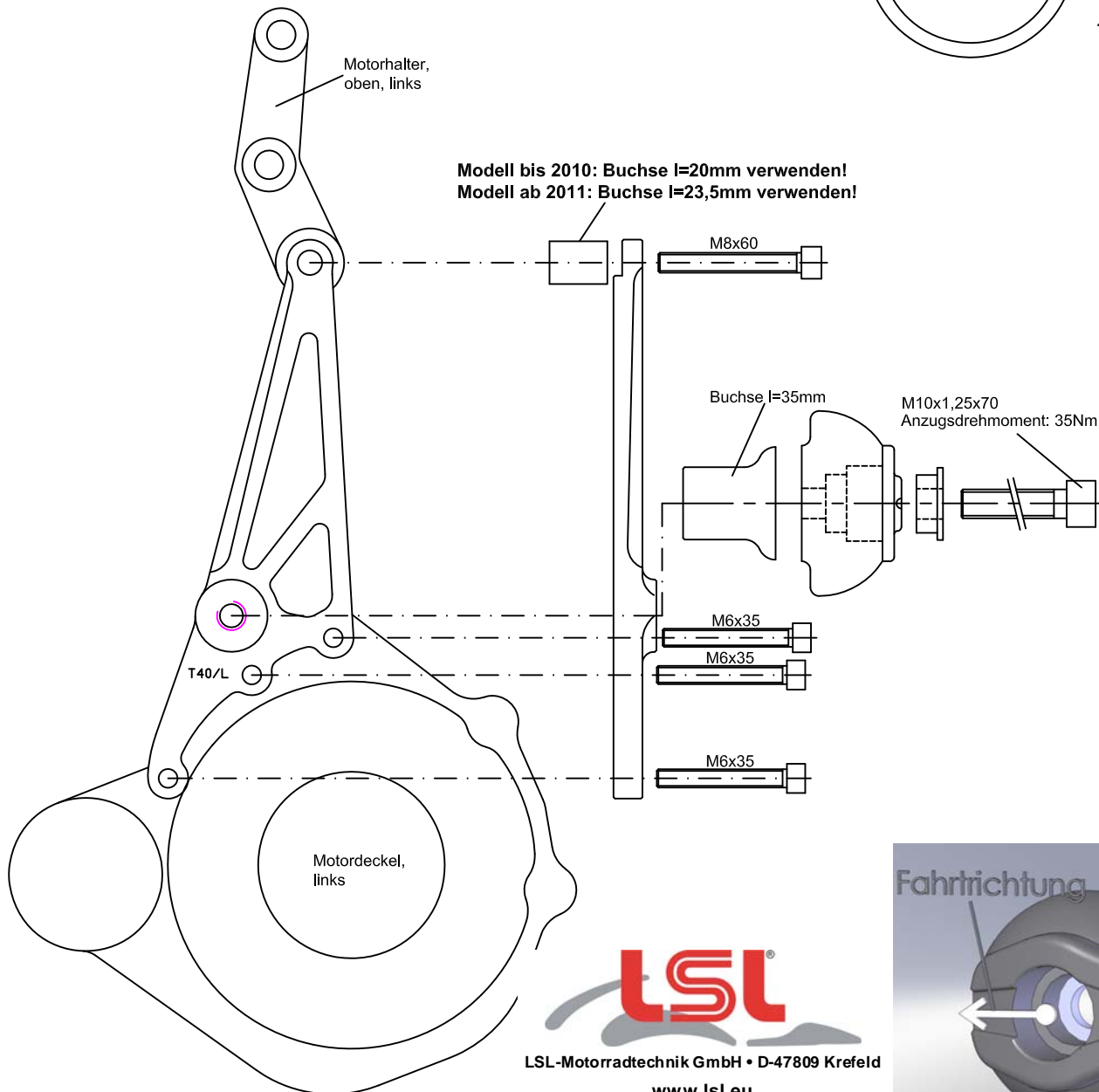

LSL-Motorradtechnik GmbH • D-47809 Krefeld

www.isl.eu

Rev. 01 07/12/2010

Fitting instruction Crash-Pads Triumph Speed Triple / Tiger 1050 Part-no.: 550T033.1

Important: If you are not a trained motorcycle mechanic stop now. Ask a local motorcycle shop to do the work for you.

The tightening torques refer to the manufacturer's instructions!

Fitting on the right side:

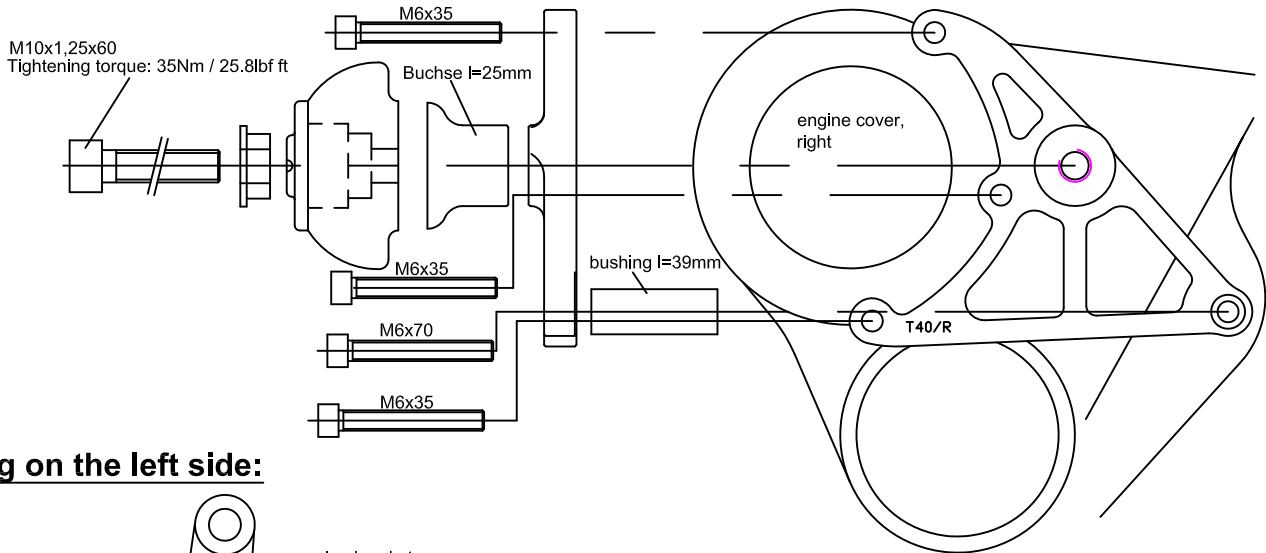

Fitting on the left side:

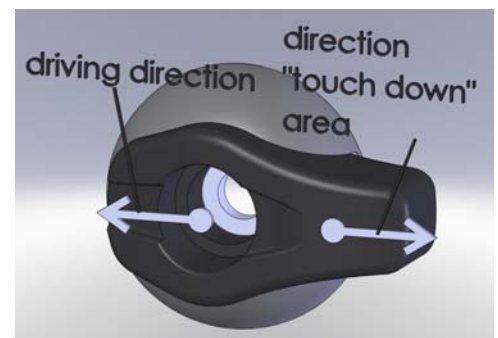
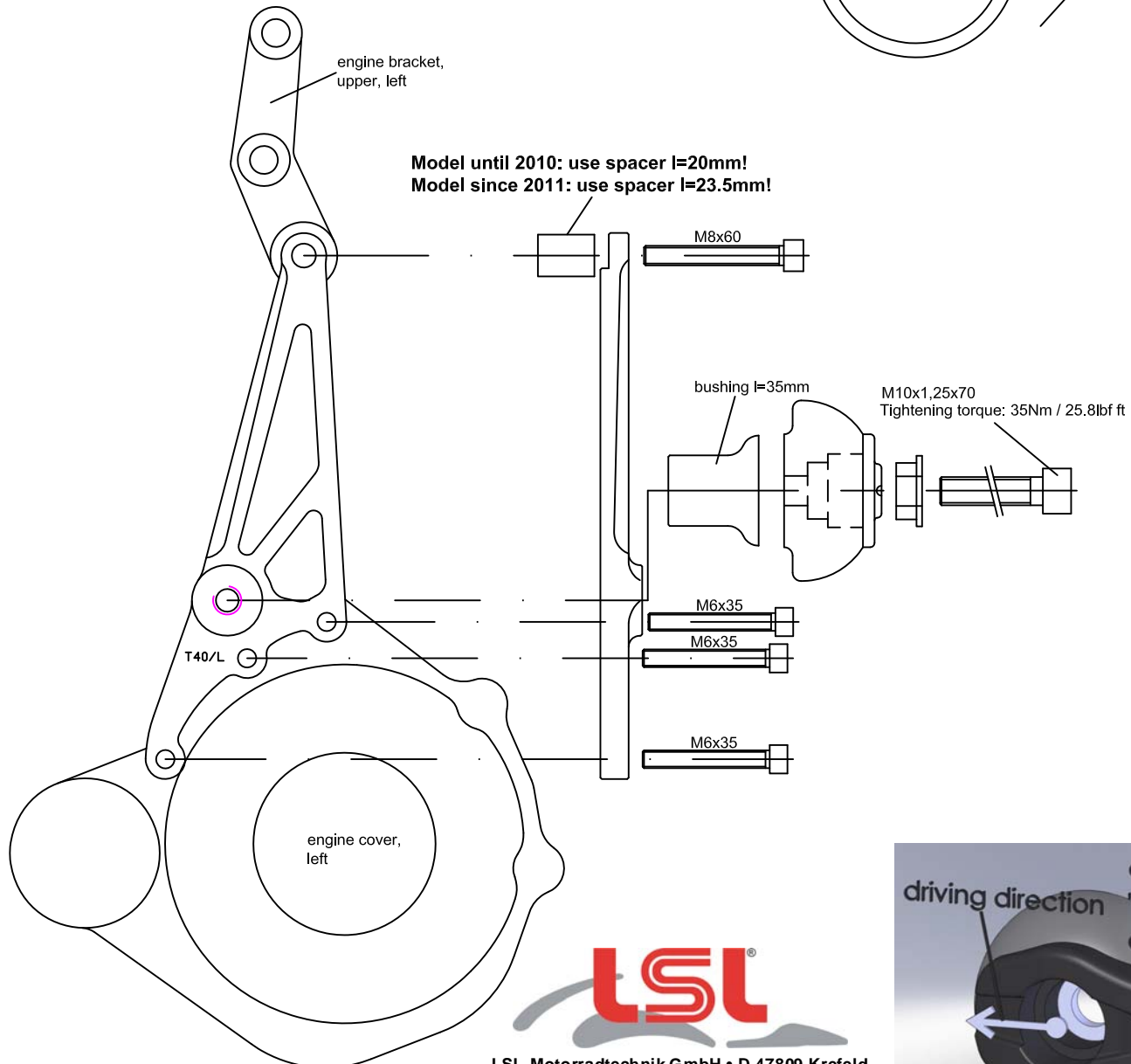

Instructions de montage des Crash-Pads pour Triumph Speed Triple/ Tiger 1050

N° article : 550T033.1

Important: Le montage doit être fait par un professionnel!

Utilisez les couples de serrage préconisés par le constructeur!

Montage côté droit:

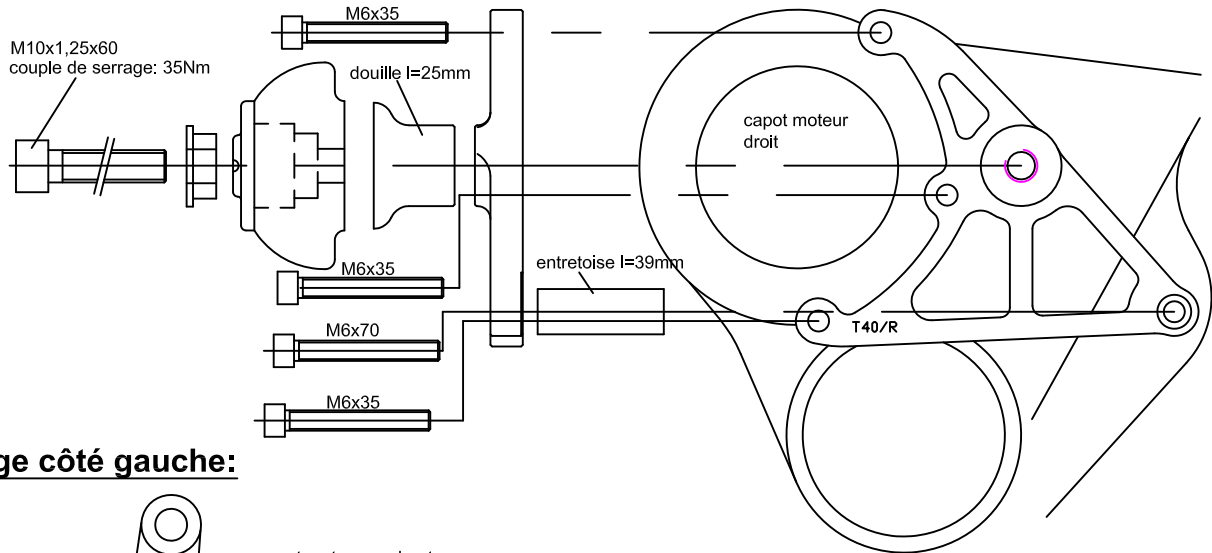

Montage côté gauche:

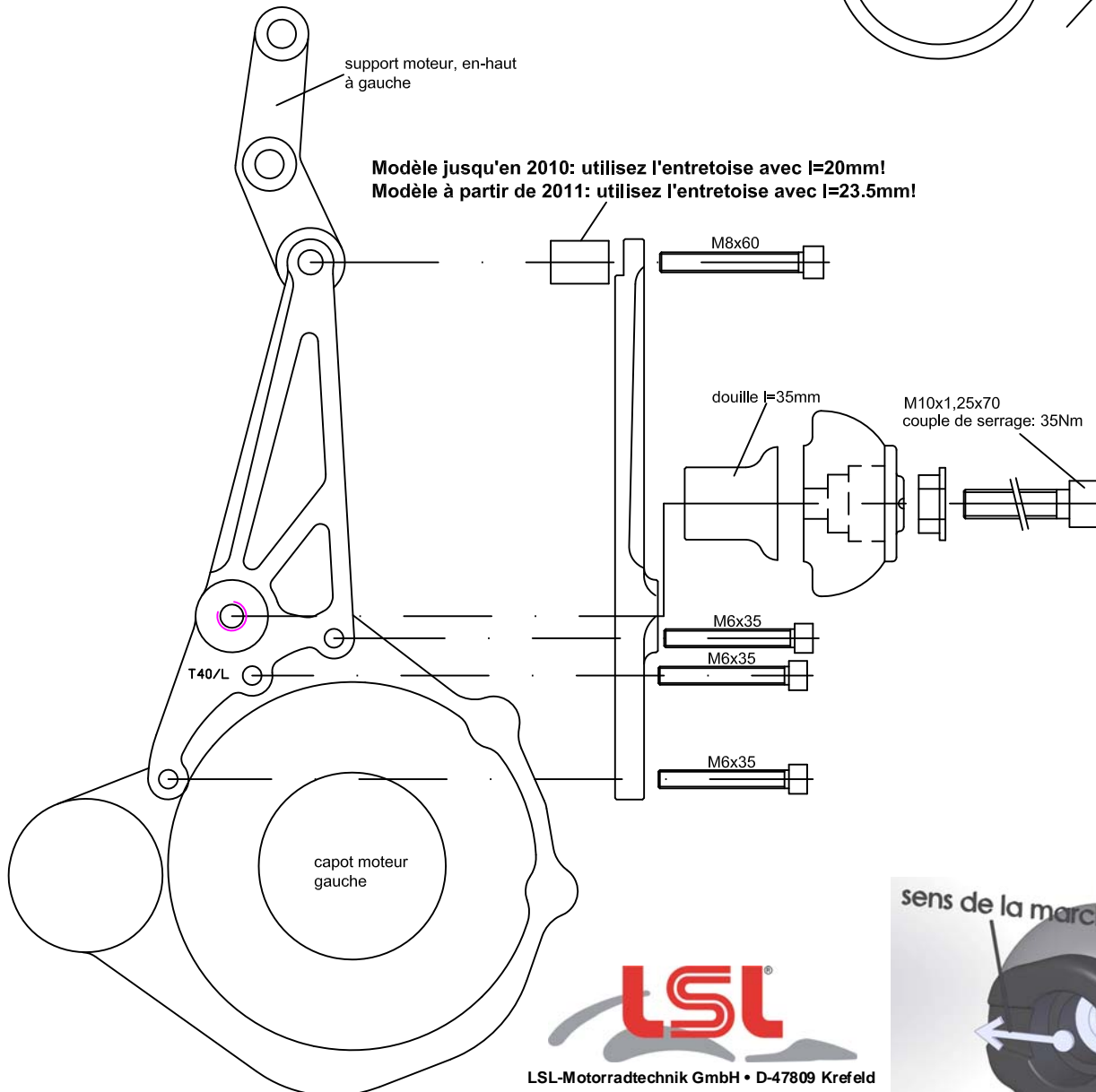

LSL-Motorradtechnik GmbH • D-47809 Krefeld

www.lsl.eu

Rev. 01 07/01/2011



LSL-Motorradtechnik GmbH • D-47809 Krefeld

www.lsl.eu