

# Anbauhinweise für Crash- Pads Triumph Bonneville/Thruxton

Art.Nr.: 550T024

**Wichtig:** Wenn Sie kein ausgebildeter Mechaniker sind, wenden Sie sich bitte an eine Fachwerkstatt.

## Anbau der rechten Seite

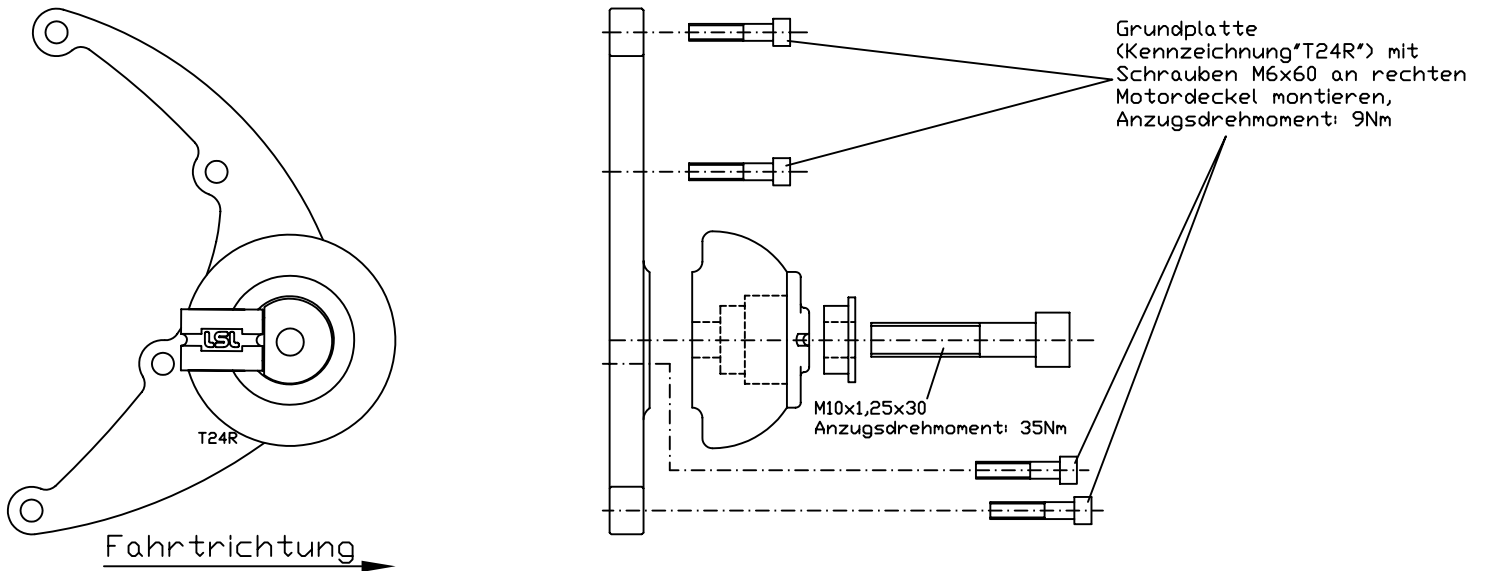

## Anbau der linken Seite

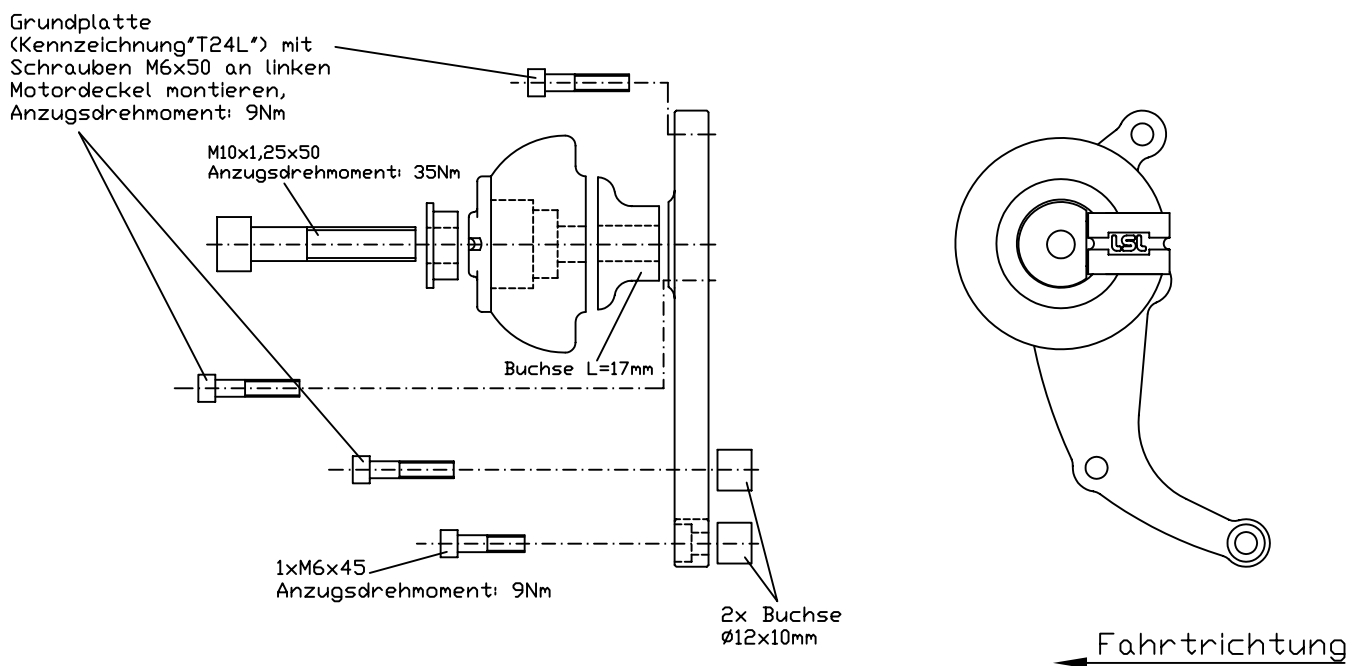

**LSU**  
MOTORRADTECHNIK

D-47809 Krefeld

[www.lsl.eu](http://www.lsl.eu)

# Fitting instruction Crash- Pad Kit Triumph Bonneville/Thruxton

Part.no.: 550T024

**Important:** If you are not a trained motorcycle mechanic stop now. Ask a local motorcycle shop to do the work for you.

## Fitting on the right side

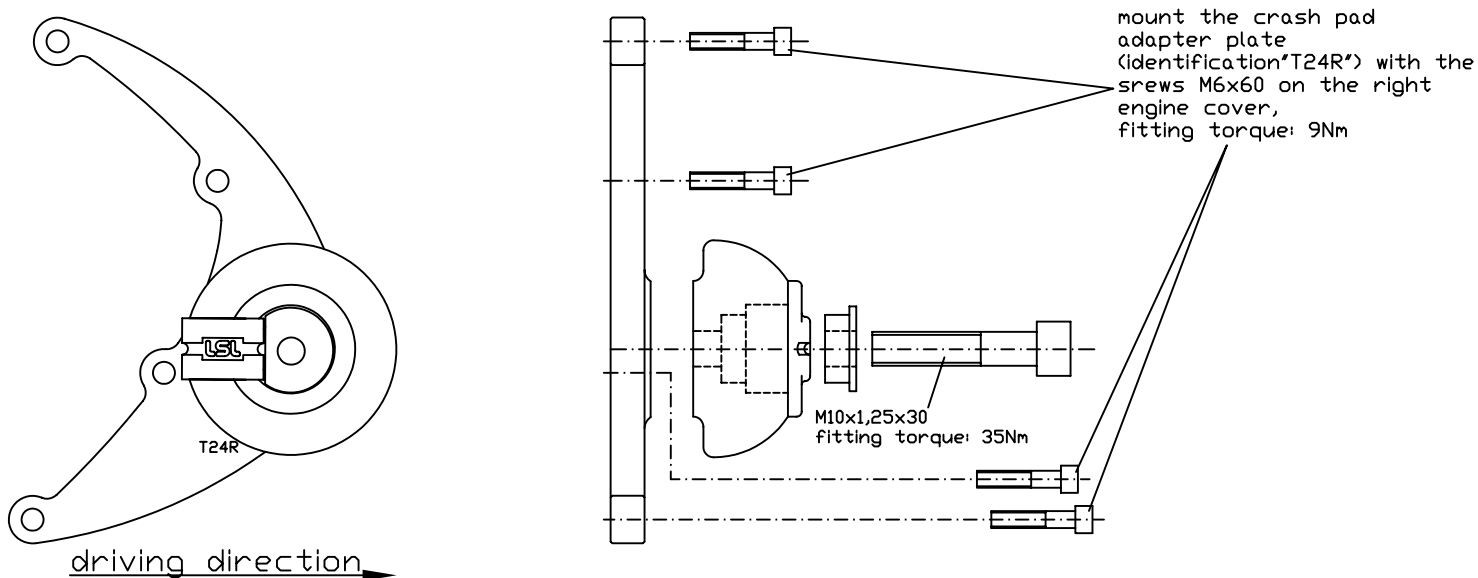

## Fitting on the left side

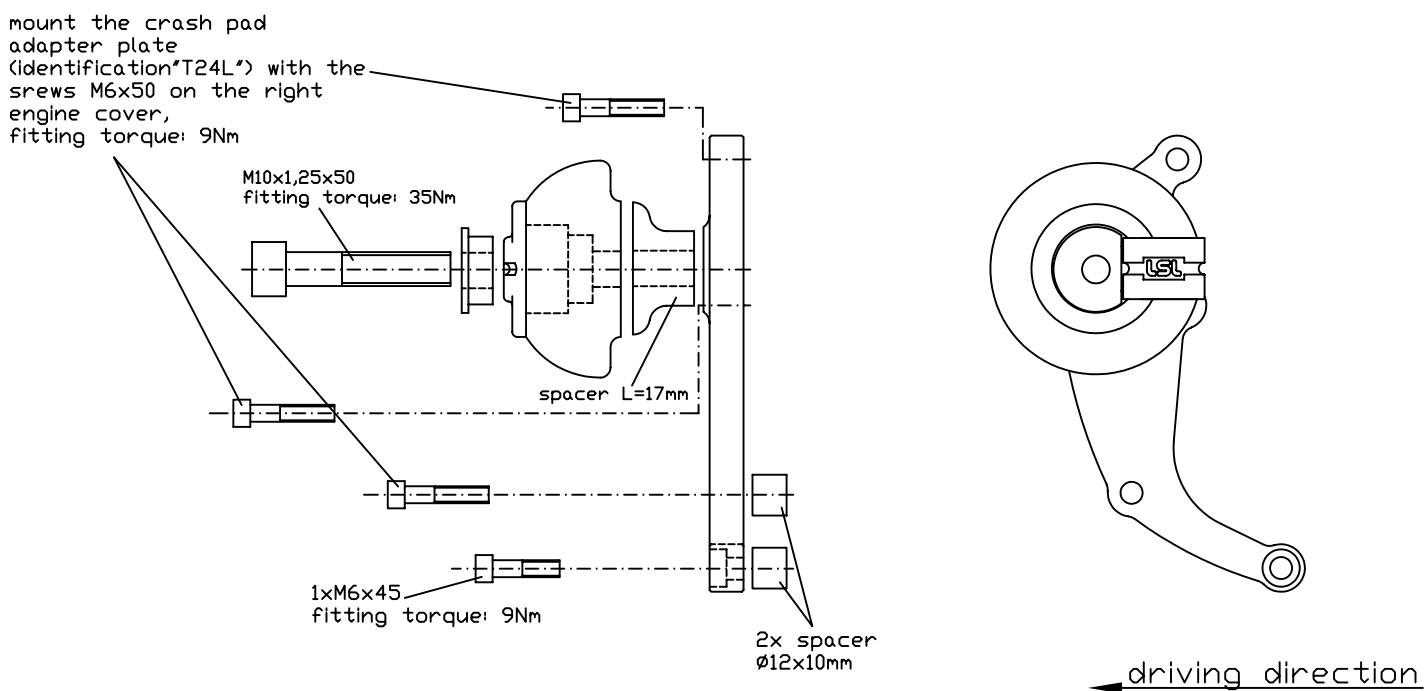

**LSU**  
MOTORRADTECHNIK

D – 47809 Krefeld

[www.lsl.eu](http://www.lsl.eu)

**Instructions de montage des Crash Pad pour Triumph Bonneville / Thruxton**  
**N° article : 550T024**

**Important:** Le montage doit être fait par un professionnel.

**Montage côté droit:**

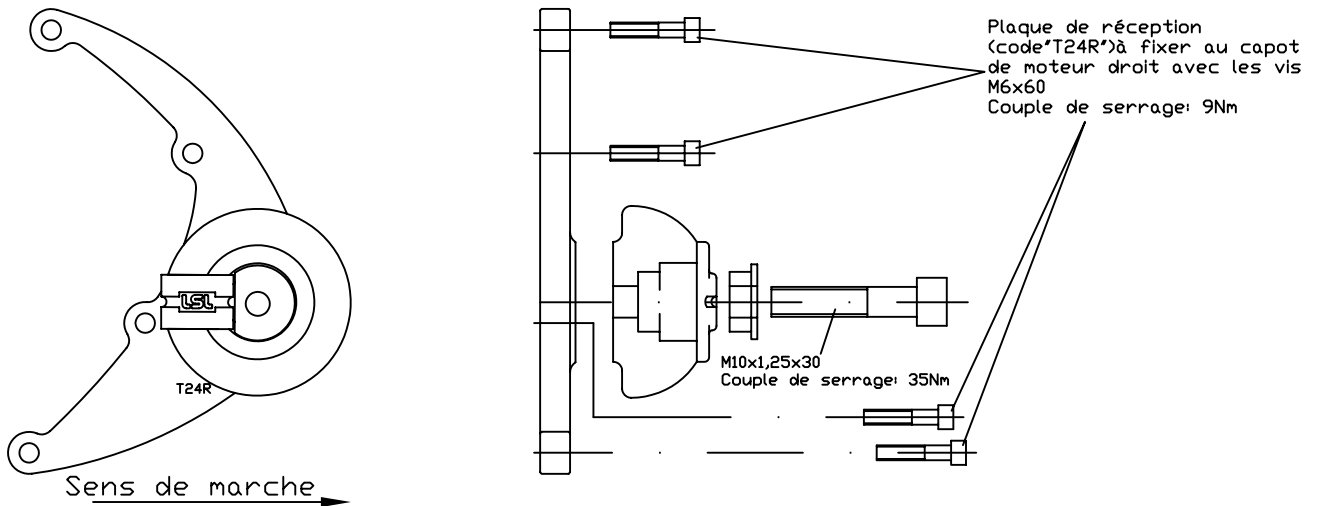

**Montage côté gauche:**

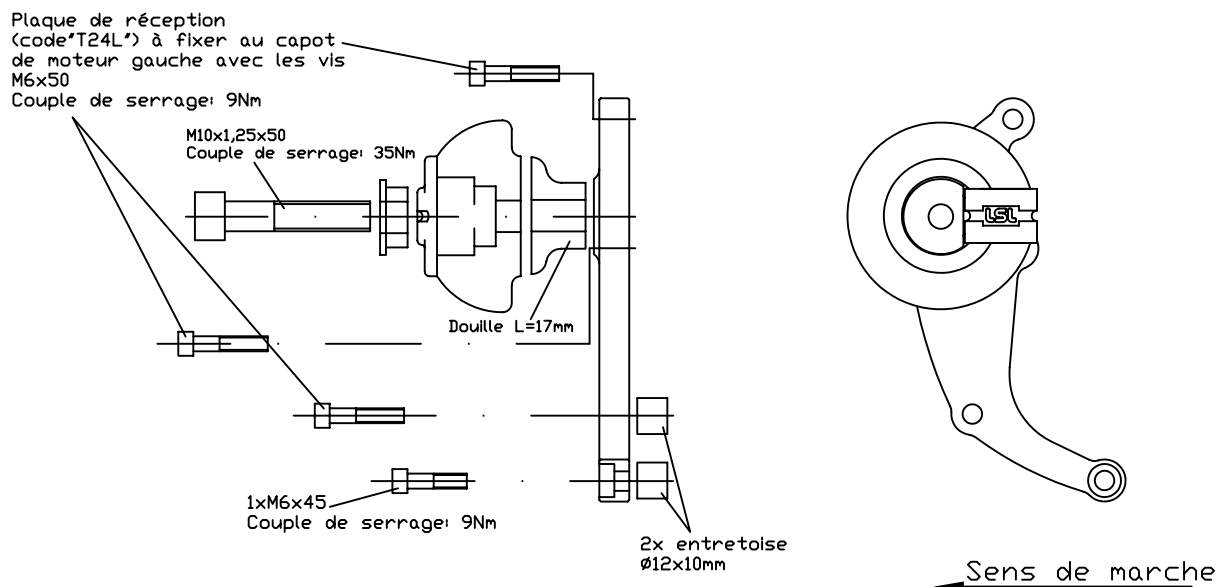

[www.lsl.eu](http://www.lsl.eu)

03/2006