

Anbauhinweise für Crash- Pads Suzuki GSX-R 600/750 `04-05 Art.Nr.: 550S097.1

Wichtig: Wenn Sie kein ausgebildeter Mechaniker sind, wenden Sie sich bitte an eine Fachwerkstatt.
Bitte unbedingt vor dem Anbau beachten!

Die Montage der Crash-Pads muss seitenweise erfolgen!

Das gleichzeitige Lösen der beiden Motorhalteschrauben ist zu vermeiden!

Verkleidungsseitenteile brauchen nicht ausgespart oder gebohrt werden!

Anbau der rechten Seite

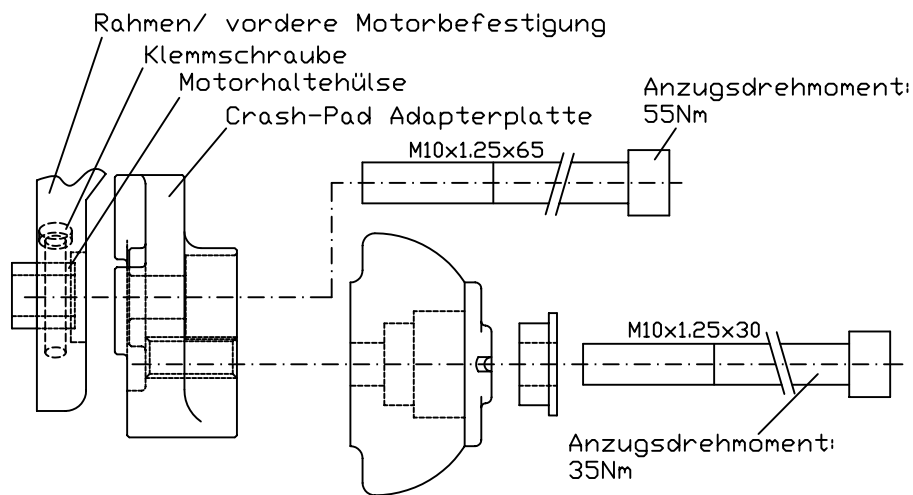

Suzuki GSX-R 600/750 ab 2004

Anbau der linken Seite

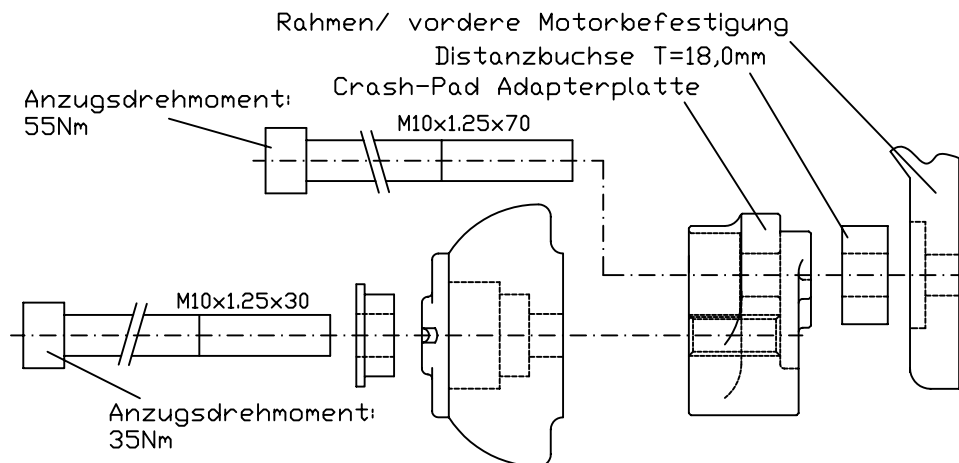

Suzuki GSX-R 600/750 ab 2004



Fitting Instructions Crash-Pads Suzuki GSX-R 600/750 '04 - '05 Part-No.: 550S097.1

Important! If you are not a trained motorcycle mechanic stop now. Ask a local motorcycle shop to do the work for you.

Please take extra care!

The mounting of the crash-pads has to be done side by side! At all times you have to prevent that the engine mounting bolts are not loose at the same moment!

The fairing has not to be cut or drilled!

Fitting on the right side

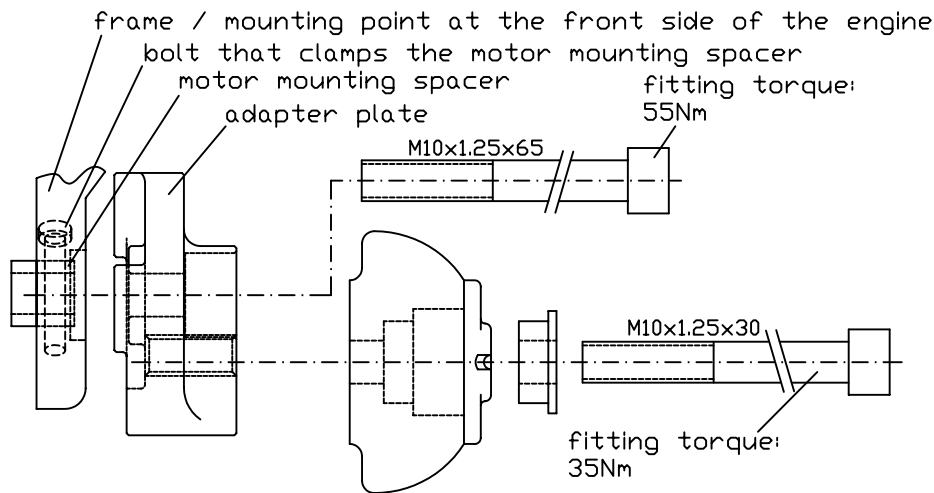

Suzuki GSX-R 600/750 ab 2004

Fitting on the left side

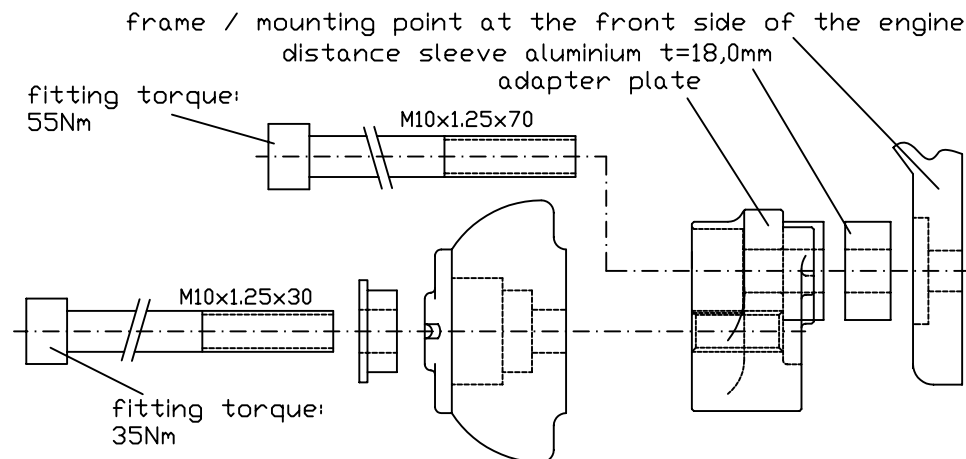

Suzuki GSX-R 600/750 ab 2004



Instructions de montage des Crash Pads pour Suzuki GSX-R 600/750 '04 - '05
N° article : 550S097.1

Important: Le montage doit être fait par un professionnel.
Le montage des Crash Pads s'effectue d'abord d'un côté et ensuite de l'autre ! Evitez le desserrage simultané des deux vis tenant le moteur!
Le carénage reste inchangé !

Montage côté droit:

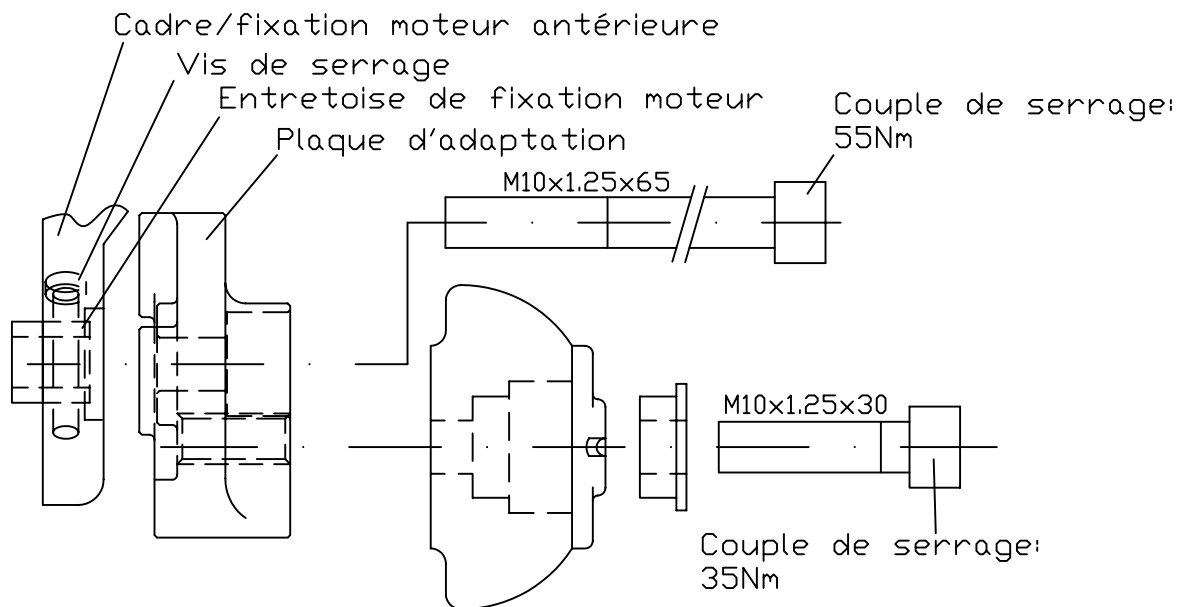

Montage côté gauche:

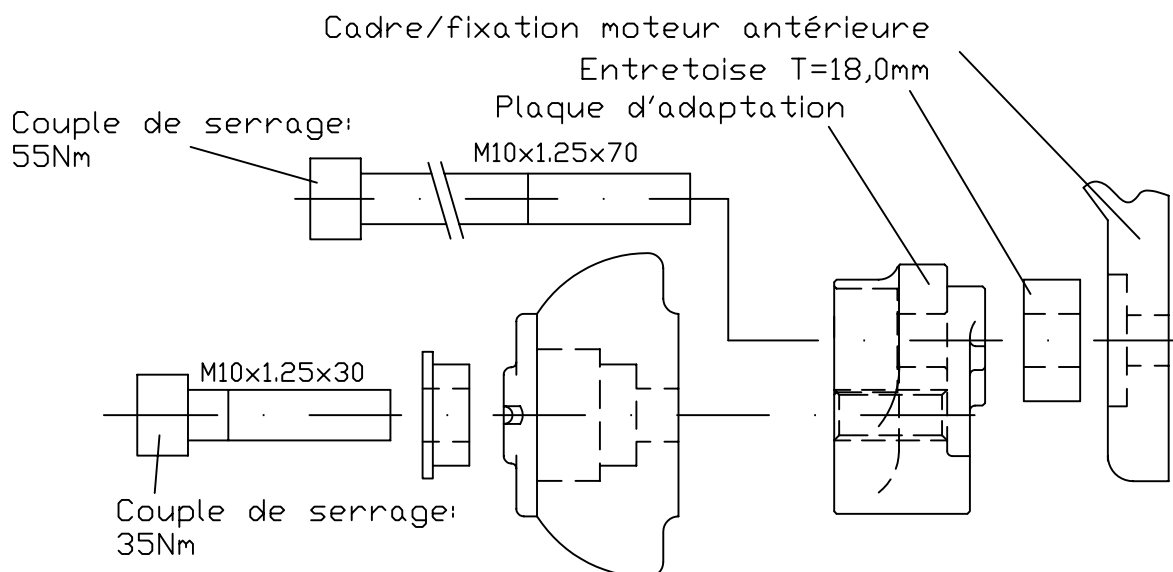

Paaschburg & Wunderlich GmbH · D-21509
www.lsl.eu



MAKING GOOD BIKES PERFECT

Paaschburg & Wunderlich GmbH · D-21509

www.lsl.eu