

Wichtig: Wenn Sie kein ausgebildeter Mechaniker sind, wenden Sie sich bitte an eine Fachwerkstatt.
Bitte unbedingt vor dem Anbau beachten:
Die Montage der Crash-Pads muss seitenweise erfolgen!
Das gleichzeitige Lösen der beiden Motorhalteschrauben ist zu vermeiden!

Anbau rechte Seite:

(Ansicht von hinten)

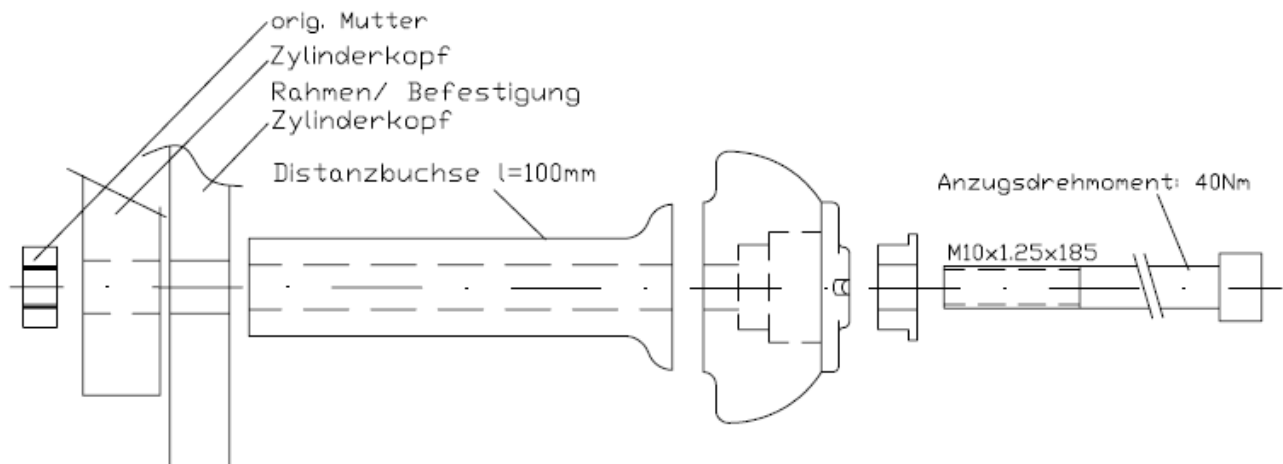

Anbau linke Seite:

(Ansicht von hinten)

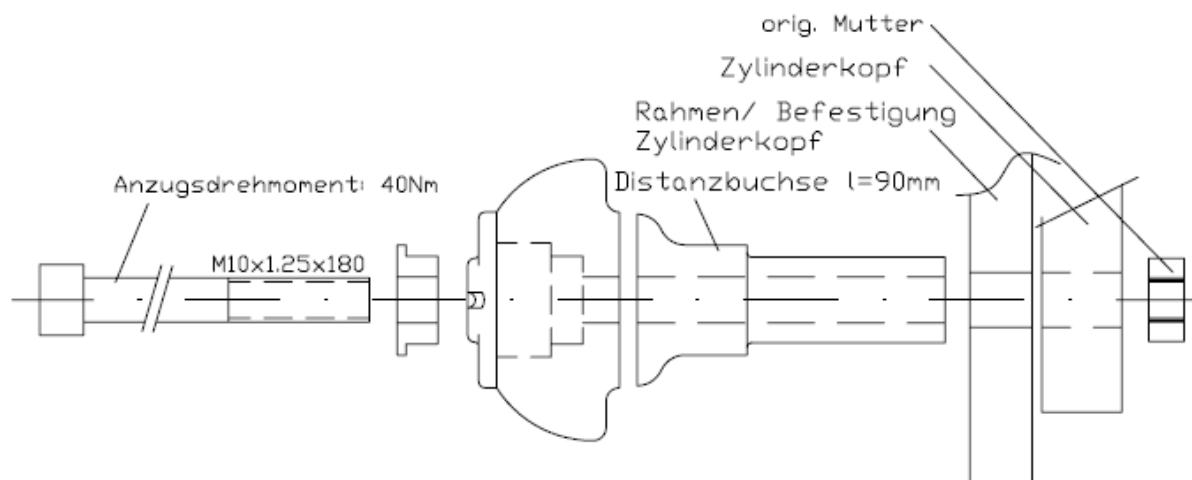

LSL-Motorradtechnik GmbH • D-47809 Krefeld
www.lsl-motorradtechnik.de

Stand:26.10.2006

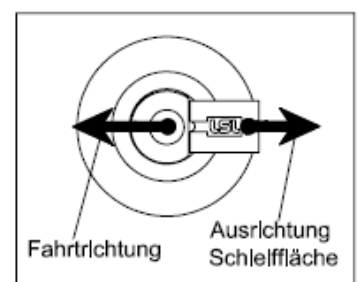

Important: If you are not a trained motorcycle mechanic stop now. Ask a local motorcycle shop to do the work for you.

Please take extra care!

You have to mount the crash-pads one side after the other! Do not loose more then one engine mounting bolt at the same time!

Fitting of the right side:

(View from the rear)

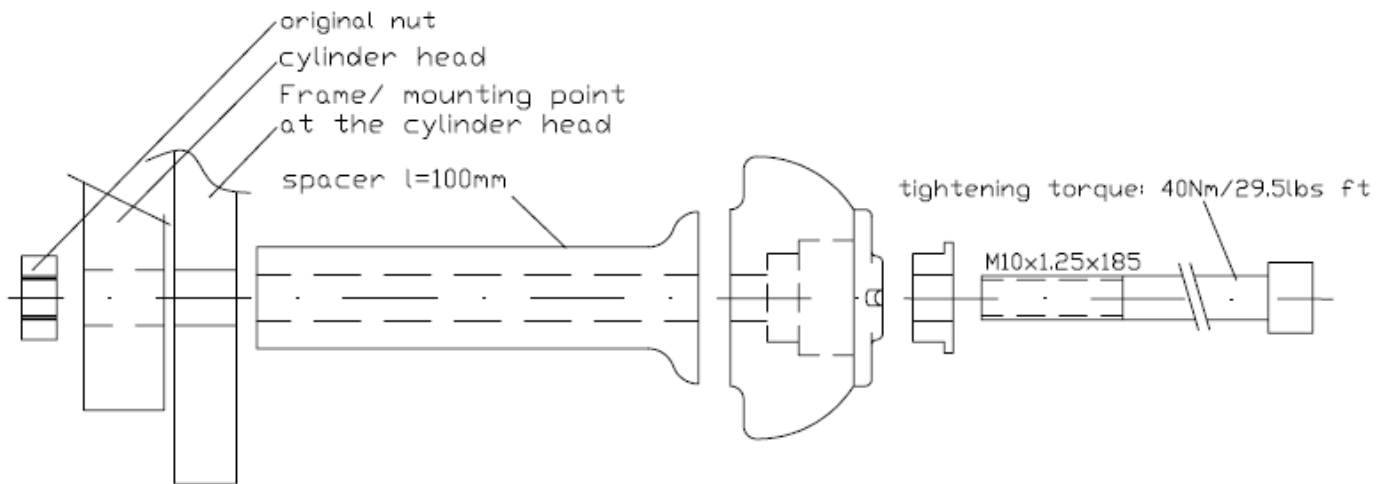

Fitting of the left side:

(View from the rear)

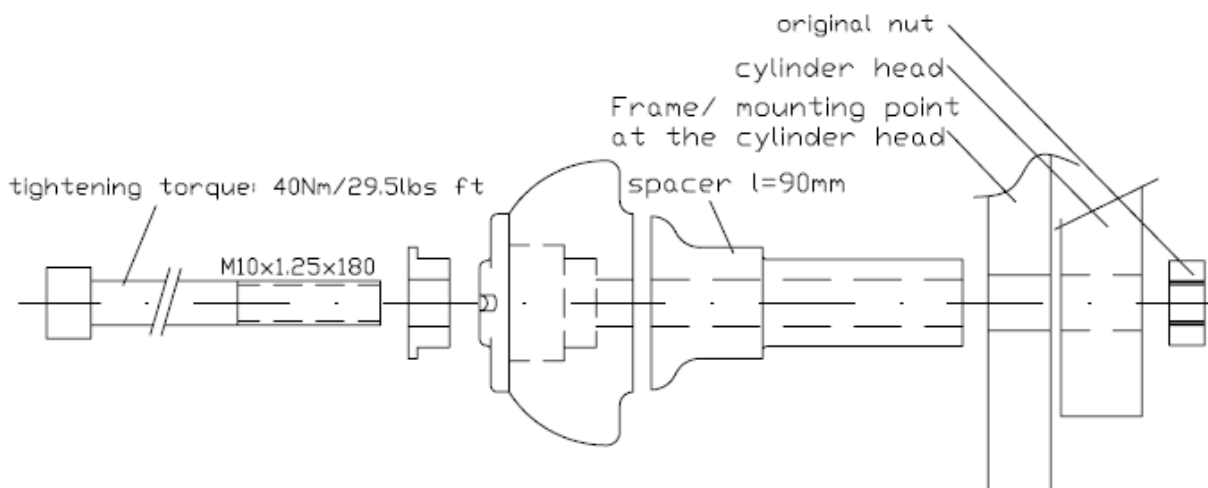

LSL-Motorradtechnik GmbH • D-47809 Krefeld
www.lsl-motorradtechnik.de

Stand: 26.10.2006

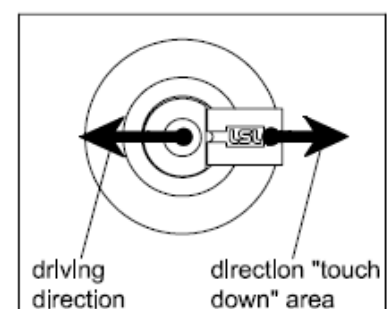

Instructions de montage des Crash-Pads pour Kawasaki Z1000 '03 - '06

N° article : 550K102

Important: Le montage doit être fait par un professionnel!
Le montage des Crash-Pads s'effectue d'abord d'un côté et ensuite de l'autre! Il faut éviter le desserrage simultané des deux vis tenant le moteur!

Montage côté droit:

(Vue arrière)

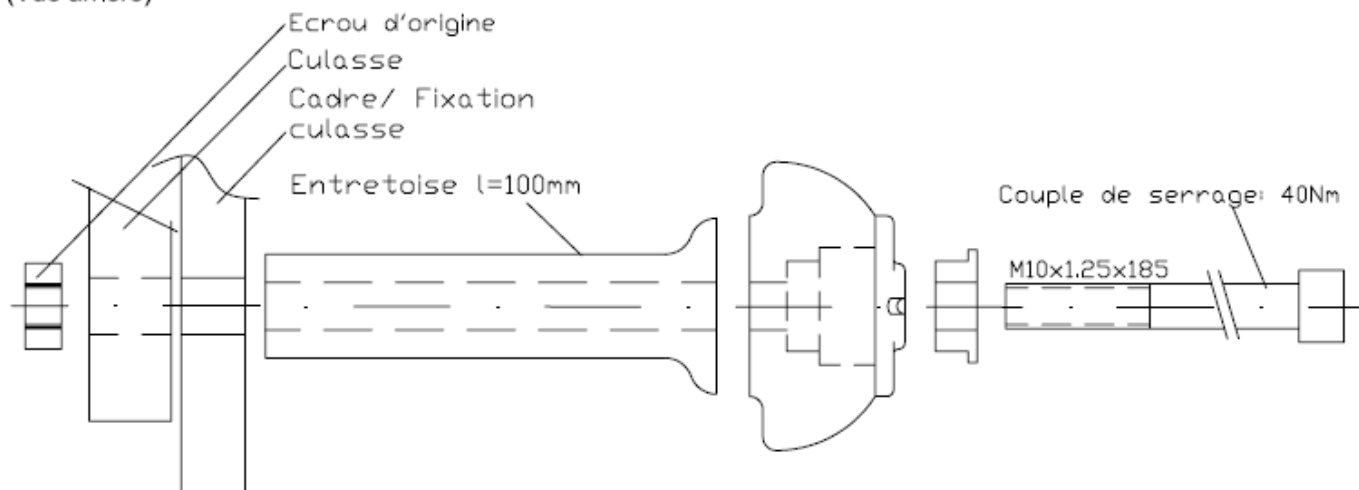

Montage côté gauche:

(Vue arrière)

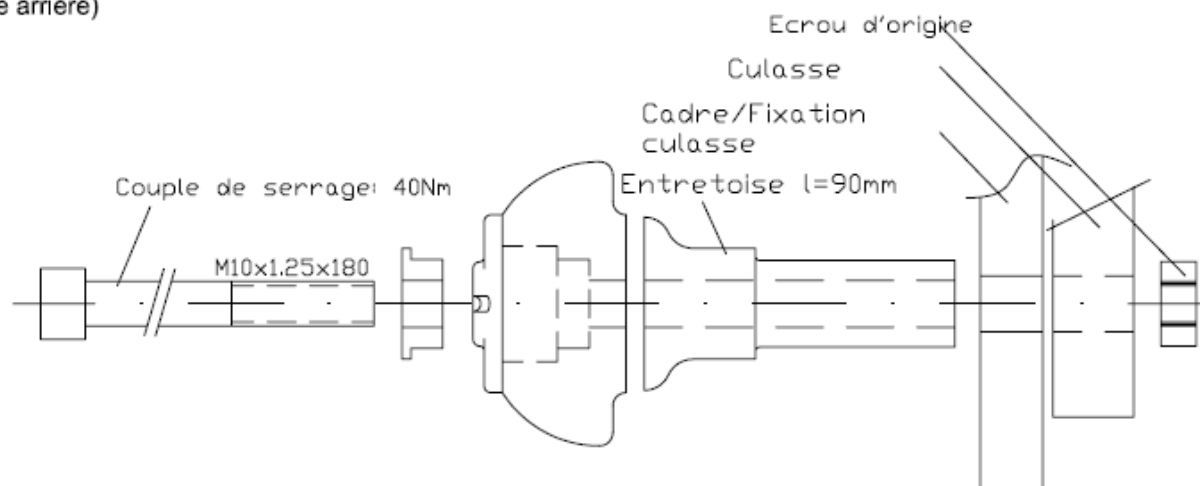

LSL-Motorradtechnik GmbH • D-47809 Krefeld

www.lsl-motorradtechnik.de

Stand:26.10.2006

